

INDUSTRIAL LIFT TRUCK SPECIFICATION SHEET

ISO Rated Container Capacity 101,400-lbs. (46,000kg)
First Row / 4-high Stacking 9.5-ft. (2.9m)

XRS-1075

Rated Container Capacity 92,600lbs (42,000kg)
First Row / 5-high Stacking 9.5-ft. (2.9m)

256-in. (6,500mm) Wheelbase



Cover image is for example purposes only and may not reflect current features.



TAYLOR MACHINE WORKS, INC.

Founded in 1927 on the principles of “FAITH - VISION - WORK”, and entrenched with decades of Heavy Industrial Material Handling experience. Taylor meets all of your rugged industrial needs with models and capacities that range from 4,000-lbs to 125,000-lbs. The Taylor X-Series features Tier 4 Final engine technology that has increased fuel efficiency while retaining the powerful low-end torque that our customers have come to expect. Taylor’s reputation was built while performing in the harshest industrial environments the Material Handling Industry has to offer. We strive to keep things simple and use appropriate technology that brings value and the Taylor XRS-1075 continues that tradition!

you can depend on *Big Red*®

Performance: †				
Travel Speed	Maximum Fwd/Rev - No Load	mph (km/h)	14.9	24.0
	Maximum Fwd/Rev - With Load	mph (km/h)	13.3	21.4
Lift Speed	Lifting	fpm (m/s)	49	0.25
	Extention	fpm (m/s)	59	0.30
Lowering Speed	Lowering	fpm (m/s)	69	0.35
	Retraction	fpm (m/s)	108	0.55
Tractive Effort	At Stall	lb (kN)	66,768	297
Gradeability	With Load	% (%)	17.0	19.5
	No Load	% (%)	29.0	29.0

† NOTE: Performance specifications are based on trucks with standard equipment. Performance specifications are affected by the condition of the vehicle, its components, and the nature and condition of the operating area. If these specifications are critical, the proposed application should be discussed with your Taylor sales representative.



XRS-1075

Engine:

Optional Engine International Shipments Only

Engine	Make & Model	Cummins X12 (Turbocharged)				Cummins X12 (Turbocharged)				
	Tier Compliance	†EU Stage V - EPA TIER 4F				††Tier 3				
	Fuel - Engine Type	Diesel - 4 Stroke				Diesel - 4 Stroke				
	Output	hp (Kw)	335	250		335	250			
	Gov'n Speed w/Load	RPM	2100			2100				
	Cyl/Displacement	cyl/cu-in (L)	6	720	11.8	6	660	10.8		
	Peak Torque*	ft-lbs/RPM (Nm/RPM)	1249	1400	1694	1400	1235	1400	1675	
Fluids	Fuel Capacity	gal (L)								
	Diesel Exhaust Fluid	gal (L)					N/A	N/A		
Electrical	Battery	Volt (2 batteries)	24				24			

† This engine requires (DEF) Diesel Exhaust Fluid and features (SCR) Selective Catalytic Reduction, (DPF) Diesel Particulate Filter, diagnostic and maintenance monitor, fuel/water separator and engine/trans. protection systems. Emission certification: US EPA Tier 4 Final

†† Standard features are electronic diagnostic and maintenance monitor, fuel/water separator and engine/transmission protection systems. Emission certification: US EPA Tier III, Carb Tier III, EU Stage III. Attention: Taylor models equipped with U.S. EPA Tier 3 certified engines are available for sale outside of the highly regulated countries of North America, Europe and Japan. Refer to the off-road diesel engine emission regulations of the specific country in question for verification.

Transmission:

Trans.	Make & Model	Dana TE-30				Dana TE-30			
	Number of Speeds	Fwd/Rev	5/3		5/3				
	Gear Change	Automatic Gearshift				Automatic Gearshift			

The 5-speed automatic powershift transmission is modulated, fully reversing and features electric declutch. Directional controls are actuated through joystick mounted push buttons. Temperature control is achieved through a separate air-to-oil cooler. The filler-pipe dipstick and large, heavy-duty oil filter are easily accessed for maintenance.

Axles:

Drive Axle	Make & Model	Wet Disc	Kessler D-102				Kessler D-102			
Steer Axle	Make & Model	Taylor				Taylor				

The bolted heavy-duty planetary drive axle utilizes wet disc brakes.

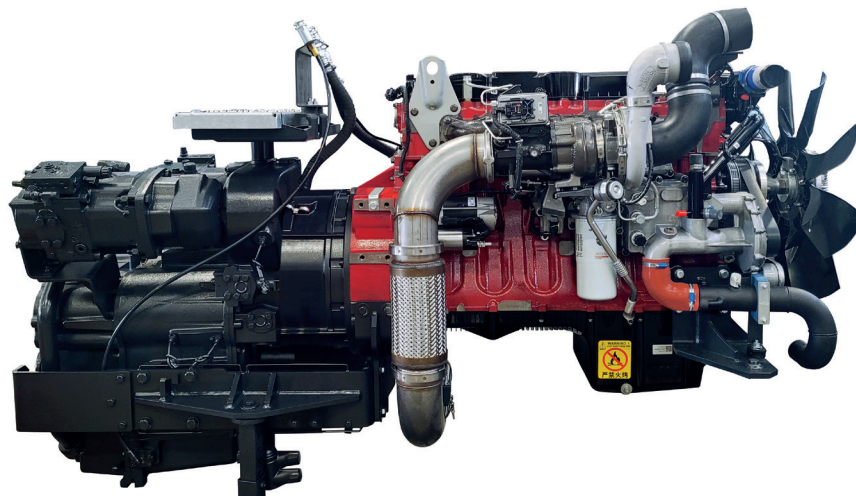

DANA TE30 Transmission

CUMMINS X12 Engine

XRS-1075 Reachstacker Dimensions:

General	Model	Manufacturer's Designation		XRS-1075		
Center of Gravity (COG) Distance from tire face to:	C1	1st Row (Center of Container) 1st Container	in (mm)	70.0	1,778	
	C1	1st Row (Center of Container) 2nd thru 5th Container	in (mm)	70.0	1,778	
	C2	2nd Row (Center of Container)	in (mm)	152.0	3,861	
	C3	3rd Row (Center of Container)	in (mm)	252.0	6,400	
	Rated Stacking Capacity: 9.5-ft Container (2.9m)		1st Row 4-High Stacking @ 70-in. (1,780 mm) COG	lb (t)	101,400	46
			1st Row 5-High Stacking @ 70-in. (1,780 mm) COG	lb (t)	92,600	42
			2nd Row 4-High Stacking @ 152-in. (3,850 mm) COG	lb (t)	75,000	34
			3rd Row 3-High Stacking @ 252-in. (6,400 mm) COG	lb (t)	39,700	18
	Lifting Eye Capacity (1)		4 total lifting eyes. Located on each corner of spreader	lb (t)	22,000	10
	Wheelbase	Y	Distance	in (mm)	256.0	6,502
Power Type		Diesel		Diesel		
Dimensions	Width	W2	Width Over Rear (steer) tires	in (mm)	132.9	3,376
		T1	Tread Width (Drive Axle)	in (mm)	119.5	3,035
		W1	Width Over Drive Tires	in (mm)	164.8	4,185
	Length	L2	Overall Chassis	in (mm)	337.0	8,560
		L1	Overall Complete Unit (Boom Down and Retracted)	in (mm)	472.4	11,999
		X	Drive Axle CL To Face Of Tires (Nominal)	in (mm)	36.6	930
	Height	H7	Height To Top Of Seat	in (mm)	111.0	2,819
		H3	Height to Top of Boom (Fully Lowered)	in (mm)	192.9	4,900
		H5	Height to Top of Boom (Fully Raised)	in (mm)	755.9	19,200
		H2	Height to Tip of Twistlock (Lowered)	in (mm)	43.3	1,100
	H4	Height to Tip of Twistlock (Raised)	in (mm)	614.2	15,601	
Underclearance	M1	Midway along the Wheelbase	in (mm)	16.5	419	
Attachment Dimensions	20-ft Container (6.1m)	Length of Attachment (Retracted)	in (mm)	240.0	6,096	
	40-ft Container (12.2m)	Length of Attachment (Expanded)	in (mm)	480.0	12,192	
		Width of Attachment (Nominal)	in (mm)	96.0	2,438	
	20-ft Container (6.1m)	Min. Aisle for 90° Stacking - Suspended Central Over Axle	in (mm)	386.0	9,804	
	40-ft Container (12.2m)	Min. Aisle for 90° Stacking - Suspended Central Over Axle	in (mm)	500.0	12,700	
	20-ft Container (6.1m)	Min. Aisle for 90° Stacking - With 8-in Ground Clearance	in (mm)	469.0	11,913	
	40-ft Container (12.2m)	Min. Aisle for 90° Stacking - With 8-in Ground Clearance	in (mm)	547.0	13,894	
		Sideshift (+/-)	in (mm)	31.5	800	
		Attachment Rotation (CW/CCW)	Degrees	105° / 195°		
		Pile Slope - Mechanical	Degrees	(±) 3°		
	Pile Slope - Hydraulic	Degrees	(±) 4°			
	Boom Angle (Max)	Degrees	60			
Turn Radius	Truck Only	R1	Minimum Outside (Tailswing)	in (mm)	330.7	8,400
		R2	Minimum Inside	in (mm)	38.6	980
Weight	Total Apprx.	Service Weight	lb (kg)	176,810	80,200	
	Axle Loading	Static with Rated Load (Front) with 99,000-lb (45T) Load	lb (kg)	231,700	105,097	
		Static with Rated Load (Rear) with 99,000-lb (45T) Load	lb (kg)	46,517	21,100	
		Static with No Load (Front)	lb (kg)	87,964	39,900	
		Static with No Load (Rear)	lb (kg)	88,846	40,300	
Wheels & Tires	Tire Type	Cushion or Pneumatic (Front / Rear)		Pneumatic / Pneumatic		
	Wheels & Tires	Number (Front / Rear)		4 / 2		
		Size (Front & Rear)		18.00 - 33 40PR		
		Inflation Pressure (Contact Pressure)	psi (bar)	145	10	
	Brakes	Service Brake		Wet Disc		
Parking Brake			Dry Disc / Transmission			
Misc.	Hydraulic Fluid	Tank Capacity	gal (L)	166	628	

XRS-1075

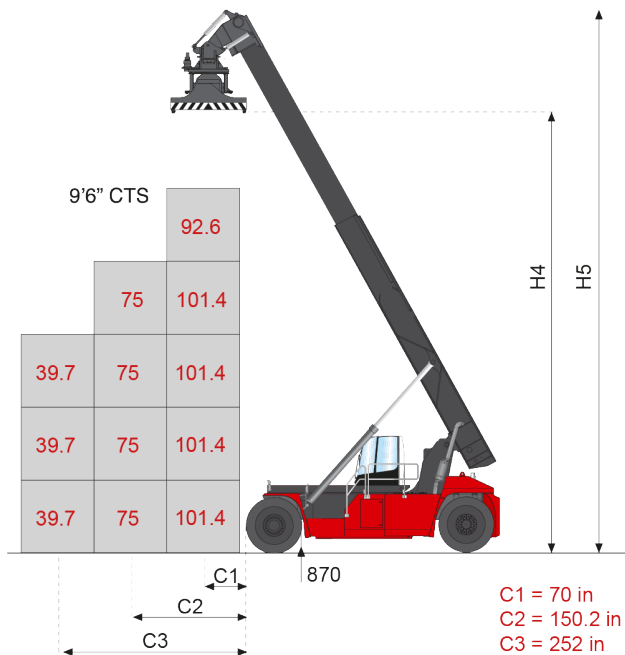
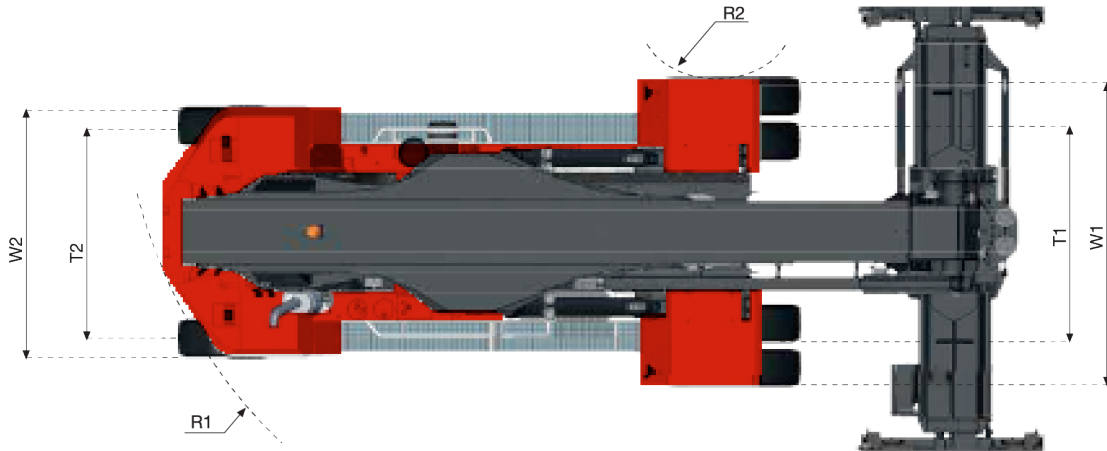
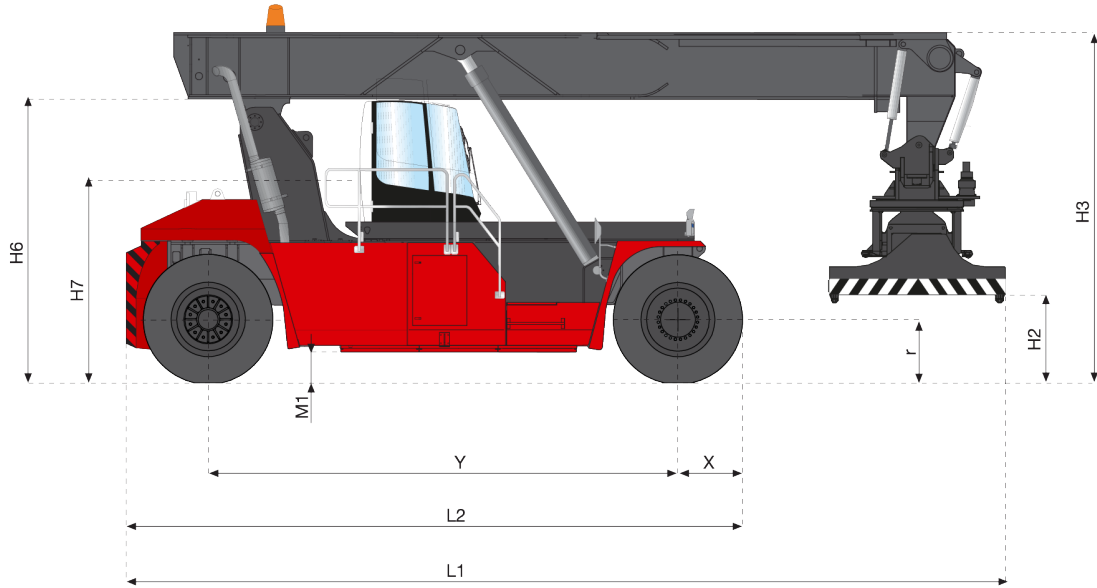

Standard Features - XRS-1075

- Telescopic Boom for stacking 5-High 1st row, 4-High 2nd row and 3-High 3rd row. (9' 6" Loaded)
- 20-40 ISO Container Handling Attachment (PPS), with rotation, side shift, expansion/retraction and damping
- Cummins X12 335-HP Tier 4-Final Diesel (Turbocharged)
- Fuel/Water separator
- Dry-type air cleaner w/safety element & restriction indicator(with Cyclonic Precleaner)
- Dana TE-30 5-speed forward, 3 speed reverse powershift transmission (with lockup)
- Powertrain protection system for engine and transmission
- Kessler D-102W HD planetary drive axle with wet disc brakes
- Taylor welded steel steer axle with stud protectors
- "Sixth sense" hydraulic system with engine power output matching
- Automatic boom adjustment for vertical lift

Chassis

- Welded high tensile steel chassis structure in accordance with DIN 15018 H2B4
- Antislip stairs for access to cabin on the left side with handrails
- Steel Front Mudguards
- Front and rear lifting eyes
- Stainless steel track chains for cabin, boom and spreader

Cab

- Center mounted sliding cabin (tracks to front of machine)
- Climate Controlled operator cabin includes right hand and left hand access doors,with rear exit window, dome light and and two circulation fans.
- Cabin heater (40,000 BTU/h) with front and rear defrosting, cab pressurizer and fresh air intake
- Cabin air conditioning (cooling power 9kW or 30.000 BTU/h) with open door auto stop
- Front, Rear, and Top Glass Wipers with Washers
- Air-suspended and heated seat with orange 3-point seatbelt
- Multifunction joystick mounted on adjustable arm rest (electronic spreader control with capacitive safety protection)
- Operator Presence System with timed idle and neutral shutdown (5 minute default)
- 7-in touch screen color display with on-board diagnostics
- Dual interior rear-view mirrors; Dual fender mounted exterior mirrors
- Rear visibility aid camera system
- Electronic system to protect against overtipping and overloading
- All wiring is color and number coded.
- Operator Platform conforms to to ISO 6055 (FOPS) standards

Electrical

- 24-volt electrical system
- Dual heavy-duty batteries (2 x 12 V / 200 Ah batteries)
- Dual Battery disconnect/lock-out switch
- 2 Sets of Amber/Green/Red Twistlock operation signal lights (mounted in cab and on boom)
- High/low beam Front halogen head lights; Front halogen position lights
- Rear LED position lights, front/side/rear indicator lights w/hazard mode
- (4) Boom mounted LED work lights
- (2) Dedicated Twistlock LED work lights
- (4) LED forward facing work lights (cabin mounted)
- LED Rear stop lights and reverse lights
- 12 V socket in the cab (max 20A converter)
- Double Electric Horns
- Keyswitch-actuated amber strobe light
- Reverse-actuated warning alarms
- Thermostatically controlled engine, transmission, and hydraulic oil cooling fans
- Pre-selection mode for stacking height and throttle cut-off during boom lowering

Vehicle Information Package

- Operators Guide
- Maintenance and Service documentation
- Safety Check Manual and Video



Fully Enclosed 2-Door Cab with Multiple Climate Control Configurations Available (featured cab is shown with available options)



Ergonomic & Serviceable Joystick (Standard)



Fully Adjustable Air Suspended and Heated Seat (Standard)



Seven Inch Display (Standard)



Adjustable, Ergonomic Armrest that is Independent from Seat (Standard)



Industry's Toughest Steer Axle (Standard)



Vehicle Information Package "VIP" (Standard)

NEED OPTIONS?

Just ask one of our Taylor Specialist.

Taylor Machine Works was founded on the promise of meeting our customer's needs. The signage on our original facility in 1927 stated "We Engineer and Build What You Need" and those ideals still ring true today! From multiple Mast, Carriage and Fork configurations to Special Attachments that are unique to your business, we will step forward to meet the challenge. We have a dedicated engineering group focused on meeting special request from our customers. This ensures that you have the exact equipment you need to tackle your rugged applications. With hundreds of options readily available for our trucks, and the ability to custom engineer any other need that arises, Taylor Machine Works is here ready to serve.

Durability and Service

Taylor Reachstackers are designed with ease of maintenance and serviceability as a key priority. With today's engine and emissions requirements, daily maintenance checks and timely periodic service are the key to your equipment's longevity. The XRS-1075 reach stacker is certified by a major international third-party inspection and verification institute and is fully compliant with standard DIN 15018/H2 B4 Classes. This machine is engineered to resist the heaviest applications in the harshest environments. The XRS-1075 has a modular design that is utilized throughout the range. This design increases reliability and parts availability. The standard sliding cab provides complete access to the engine and transmission bays. To maximize service convenience, fluid level check and refill points are easily accessible by a wide and safe standing platform. By using CAN-BUS components, the electronics have been reduced to a minimum. They are safely enclosed in an IP67 proof casting, and the cabling is certified to -40 degree temperature.



FOPS Compliant Top Glass for optimal Driver Visibility (Standard)



Large Hydraulic & Transmission Oil Cooling System

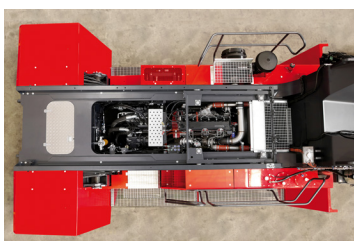

Easy Access to Drive Train & Hydraulics

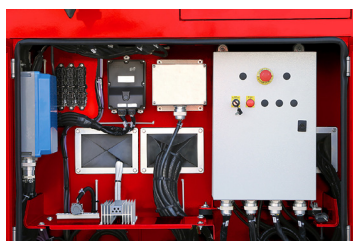

All-Weather Proof Connectors and Junction Boxes (Standard)

Hydraulics

The XRS-1075 incorporates electronic controlled hydraulics. Load sensing distribution valves, managed by the Sixth Sense software, react quicker to power demand and modulation than conventional systems. Sixth Sense is included in the standard Energy Savings Solutions (ESS) package that eliminates unnecessary fuel consumption without impairing productivity. Other standard features on the ESS package are smart engine RPM management, hydraulic driven aircon compressor, and cab temperature management as well as thermostatically controlled fans.

On Board Computer System

The XRS-1075 is equipped with a powerful on-board computer that provides the driver with operational aids and enhanced safety awareness. The system also allows a detailed user-friendly diagnostic of the machine's main systems and records functional and operational events. The core of the system is its color, extra wide 7-inch display. Interaction with the system is made through the function buttons (located on the sides) and the navigation buttons (located on the bottom).

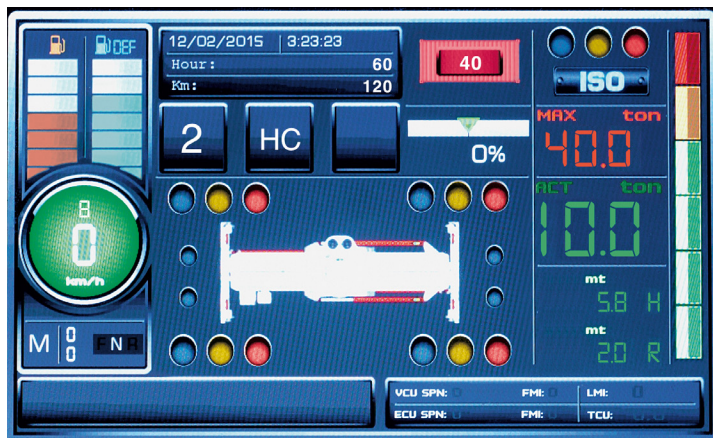

DISCLAIMER:

This vehicle is certified to meet the applicable design and performance criteria required for Powered Industrial Trucks in OSHA Safety and Health Standards, Title 29 CFR, Part 1910.178, and the applicable design and performance requirements in ANSI B56.1 that were in effect at the time of manufacture. These standards also apply to the user and should be adhered to while operating this vehicle.

All specifications are subject to change without notice. Some operating data may be affected by the condition of the vehicle, how it is operated and the nature and condition of the operating area. If these specifications are critical, contact the factory.



www.taylorsuddenservice.com

24/7 Worldwide Support

No-one can match our record for service and reliability.
Unbeatable customer service, backed by over 90 years of customer satisfaction.



Taylor Machine Works, Inc.
3690 North Church Avenue
Louisville, MS 39339
www.taylorforklifts.com