

INDUSTRIAL LIFT TRUCK SPECIFICATION SHEET

GTX-205/6

Rated Capacity for 9.5-ft. (2.9m) High Containers:
20,000-lbs. (9,072 kg) / 5-high Stacking

Rated Capacity for 8.5-ft. (2.6m) High Containers:
20,000-lbs. (9,072 kg) / 6-high Stacking
96-in. (2438 mm) Load Center
187-in. (4750 mm) Wheelbase



Cover image is for example purposes only and may not reflect current features.



TAYLOR MACHINE WORKS, INC.

Founded in 1927 on the principles of “FAITH - VISION - WORK”, and entrenched with decades of Heavy Industrial Material Handling experience. Taylor meets all of your rugged industrial needs with models and capacities that range from 4,000-lbs to 125,000-lbs. The Taylor GTX-Series features Tier 4 Final engine technology that has increased fuel efficiency while retaining the powerful low-end torque that our customers have come to expect. Taylor’s reputation was built while performing in the harshest industrial environments the Material Handling Industry has to offer. We strive to keep things simple and use appropriate technology that brings value and the Taylor GTX-205/6 continues that tradition!

you can depend on *Big Red*®

Performance: †

GTX-205/6

Travel Speed	Maximum Fwd/Rev - No Load	mph (km/h)	25.0	40.2
	Maximum Fwd/Rev - With Load	mph (km/h)	24.0	38.6
Lift Speed	No Load	fpm (m/s)	118	0.60
	With Load	fpm (m/s)	98	0.50
Lowering Speed	No Load	fpm (m/s)	98	0.50
	With Load	fpm (m/s)	98	0.50
Gradeability	No Load*	%	40	
	With Load*	%	36	
Tractive Effort	At Stall	lb (kN)	45,861	204

*PowerShift (Maximum @ Stall)

† NOTE: Performance specifications are based on trucks with standard equipment. Performance specifications are affected by the condition of the vehicle, its components, and the nature and condition of the operating area. If these specifications are critical, the proposed application should be discussed with your Taylor sales representative.

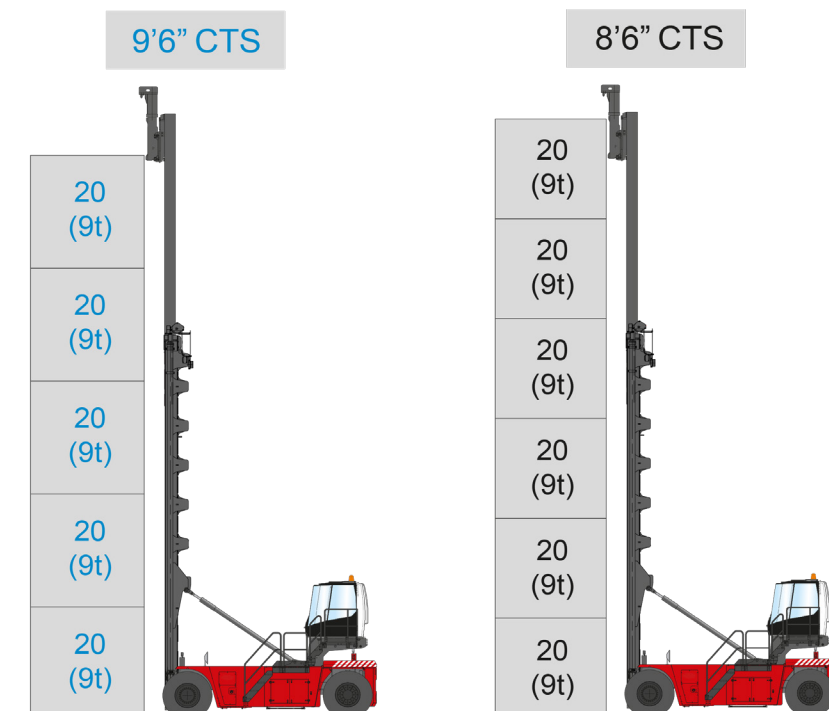

GTX-205/6

Engine:

Optional Engine International Shipments Only

Engine	Make & Model	Cummins QSB 6.7				Cummins QSB 6.7				
	Tier Compliance	Tier 4 Final				Tier 3				
	Fuel - Engine Type	Diesel - 4 Stroke				Diesel - 4 Stroke				
	Rated Output	hp (Kw)	225	168	220	164				
	Maximum Output	hp (Kw)	252	188	231	172				
	Gov'n Speed w/Load	RPM	2200				2200			
	Cyl/Displacement	cyl/cu-in (L)	6	409	6.7	6	409	6.7		
	Peak Torque*	ft-lbs/RPM (Nm/RPM)	700	1500	949	1500	875	1300	1187	
Fluids	Fuel Capacity	gal (L)	0	0	0	0				
	Diesel Exhaust Fluid	gal (L)	0.0	0			N/A			
Electrical	Battery	Volt/Ah (2 batteries)	24 / 2300				24 / 2300			
	Alternator	Amps	110				110			

† This engine requires (DEF) Diesel Exhaust Fluid and features (SCR) Selective Catalytic Reduction, (CEGR) Cooled Exhaust Gas Recirculation, diagnostic and maintenance monitor, fuel/water separator and engine/trans. protection systems. Emission certification: US EPA Tier 4 Final

†† Standard features are electronic diagnostic and maintenance monitor, fuel/water separator and engine/transmission protection systems. Emission certification: US EPA Tier III, Carb Tier III, EU Stage III. Attention: Taylor models equipped with U.S. EPA Tier 3 certified engines are available for sale outside of the highly regulated countries of North America, Europe and Japan. Refer to the off-road diesel engine emission regulations of the specific country in question for verification.

Transmission:

Trans.	Make & Model	Dana TE-17 Powershift				Dana TE-17 Powershift				
	Number of Speeds	Fwd/Rev	3/3				3/3			
	Clutch		Declutch				Declutch			

The 3-speed automatic powershift transmission is modulated, fully reversing and features electric declutch. Directional controls are actuated through a column mounted shift lever. Temperature control is achieved through a separate air-to-oil cooler. The filler-pipe dipstick and large, heavy-duty oil filter are easily accessed for maintenance.

Axles:

Drive Axle	Make & Model	Wet Disc	Kessler D-81				Kessler D-81			
Steer Axle	Make & Model		Taylor				Taylor			

The bolted heavy-duty planetary drive axle utilizes wet disc brakes.



DANA TE17 Transmission



CUMMINS QSB 6.7 Engine

Empty Container Truck Dimensions:

General		Model	Manufacturer's Designation	GTX-205/6		
	Load Center		Center of Load to Center of Axle	in (mm)	96.0 2,438	
	Rated Capacity		5-High Stacking 9.5-ft (2.9m) Container	lb (kg)	20,000 9,072	
			6-High Stacking 8.5-ft (2.6m) Container	lb (kg)	20,000 9,072	
	Wheelbase	G1	Distance	in (mm)	187.0 4,750	
	Power Type		Diesel		Diesel	
Dimensions	Tilt Angle		Standard Upright - FWD/Backward	Degrees	3/5	
	Overall Dimensions	L1	Overall Length	in (mm)	268.5 6,820	
		T2	Tread Width (Steer Axle)	in (mm)	98.0 2,490	
		T1	Tread Width (Drive Axle)	in (mm)	129.5 3,290	
		W2	Width (Over Counterweight/Fenders)	in (mm)	119.3 3,030	
			Steer Axle CL to Rear of Counterweight	in (mm)	33.5 850	
	H3	Overall Height (Lowered)	in (mm)	374.0 9,500		
	H5	Height (Mast Fully Raised)	in (mm)	651.6 16,550		
	H7	Seat Height (S.I.P.)	in (mm)	119.9 3,045		
	H6	Height (Top of Overhead Guard/Cab)	in (mm)	162.2 4,120		
	X	Center of Drive Axle to Attachment and Container Face	in (mm)	48.0 1,219		
		H2	Height to Tip of Twistlock (Lowered)	in (mm)	90.6 2,300	
			Height to Tip of Twistlock (Raised)	in (mm)	641.7 16,300	
		Ground Clearance	M1	Lowest Point	in (mm)	10.6 270
	Attachment Dimensions	20-ft Container (6.1m)		Length of Attachment (Retracted)	in (mm)	240.0 6,096
40-ft Container (12.2m)			Length of Attachment (Expanded)	in (mm)	480.0 12,192	
	20-ft Container (6.1m)		Pile Slope - Non-Powered	in (mm)	7.9 200	
	40-ft Container (12.2m)		Pile Slope - Non-Powered	in (mm)	7.9 200	
			Sideshift	in (mm)	23.6 600	
Turn Radius	Truck Only	R1	Minimum Outside (Tailswing)	in (mm)	251.0 6,375	
		R2	Minimum Inside	in (mm)	15.0 381	
Weight	Total Apprx.(Empty)		Standard Truck	lb (kg)	88,405 40,100	
	Axle Loading		Static with Rated Load (Front)	lb (kg)	90,169 40,900	
			Static with Rated Load (Rear)	lb (kg)	20,283 9,200	
			Static with No Load (Front)	lb (kg)	56,438 25,600	
			Static with No Load (Rear)	lb (kg)	31,967 14,500	
Wheels & Tires	Tire Type		Cushion or Pneumatic (Front / Rear)		Pneumatic / Pneumatic	
	Wheels		Number (Front / Rear)		4 / 2	
	Tires		Number (Front / Rear)			4 / 2
			Size (Front)			14.00 X 24
			Size (Rear)			14.00 X 24
	Brakes			System Type		Wet Disc
				Control Method (Service / Parking)		Foot / Hand
				Operation Method (Service / Parking)		Hyd / Spring

GTX-205/6

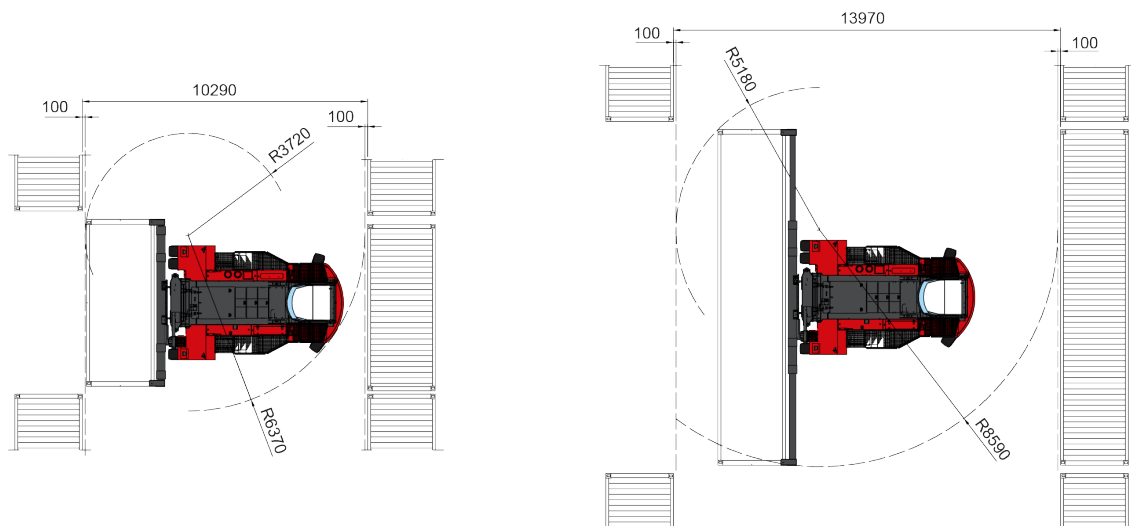
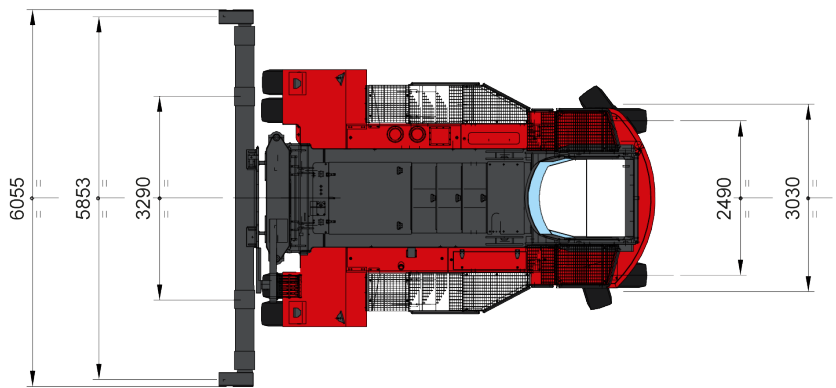
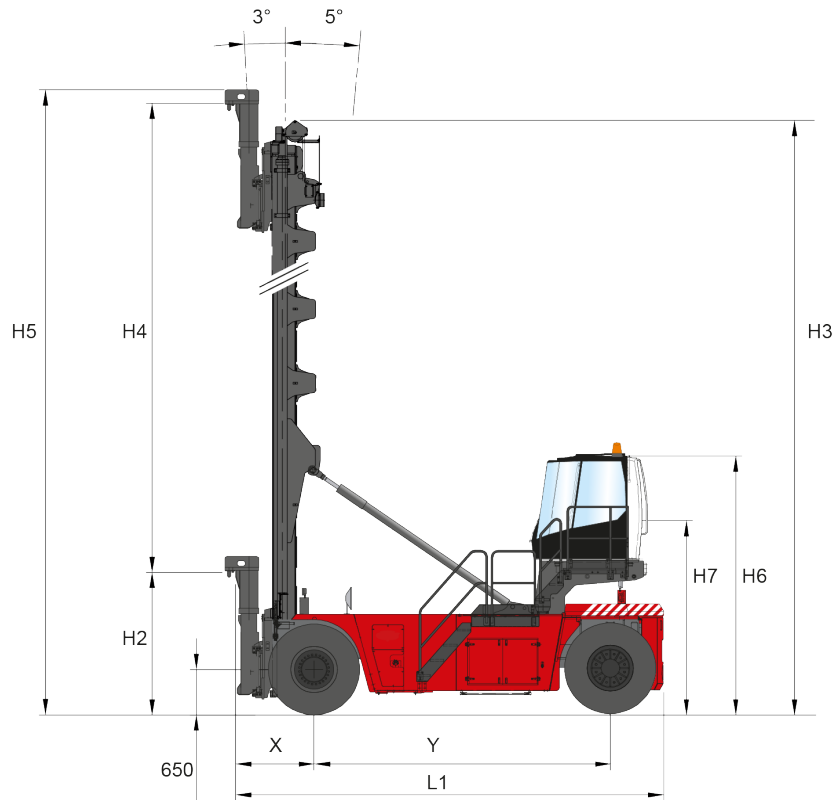

Standard Features - GTX-205/6

- Telescopic Mast for stacking 5-High (9' 6" Empty)
- 20-40 ISO Container Handling Attachment, Chain Suspended, side shift, and mechanical pile slope
- "Sixth sense" hydraulic system with engine power output matching for longer engine life
- CUMMINS B6.7 225-HP Tier 4-Final Diesel (Turbocharged)
- Donaldson dry-type air cleaner w/safety element & restriction indicator
- Dana TE-17 3-speed powershift transmission
- Powertrain protection system for engine and transmission
- Kessler D-81 HD drive axle with wet disc brakes
- Taylor welded steel steer axle
- 14.00 X 24 pneumatic drive and steer tires

Chassis

- Welded high tensile steel chassis structure (CE) in accordance with DIN 15018
- Lifting eyes, front and rear
- Antislip stairs for access to cabin with handrails
- Steel front mudguards

Cab

- Climate Controlled operator cabin includes right hand and left hand access doors, with rear exit window, dome light and and two circulation fans.
- Cabin heater (40,000 BTU/h) with front and rear defrosting, cab pressurizer and fresh air intake
- Cabin air conditioning (cooling power 9kW or 30,000 BTU/h) with open door auto stop.
- Front, Rear, and Top Glass Wipers with Washers
- Air-suspended and heated seat with orange 3-point seatbelt
- Multifunction joystick mounted on adjustable arm rest (electronic spreader control with capacitive safety protection)
- Operator Presence System with timed idle and neutral shutdown
- 7-in touch screen color display with on-board diagnostics
- Dual interior rear-view mirrors; Dual fender mounted exterior mirrors
- Rear visibility aid camera system
- Electronic system to protect against overtilting and overloading
- All wiring is color and number coded.
- Operator Platform conforms to ISO 6055 (FOPS) standards

Electrical

- Electrical system: 24 Volt (2 x 12 V / 200 Ah batteries)
- CAN BUS communication protocol
- Electronic system to protect against overtilting and overloading
- Double Electric Horns
- Keyswitch-actuated amber strobe light
- Reverse-actuated warning alarms
- High/low beam Front halogen head lights; Front halogen position lights
- Rear LED position lights, front/side/rear indicator lights w/hazard mode
- LED Rear stop lights and reverse lights
- 2x LED work lights on Spreader; 2x LED work lights on mast
- 4x LED front work lights on cabin
- Fully protected electrical components (enclosed in IP67 weatherproof box)
- 12 V socket in the cab (max 20A converter)
- Camera with color screen for rear visibility

Vehicle Information Package

- Operators Guide
- Maintenance and Service documentation
- Safety Check Manual



Fully Enclosed 2 Door Cab with Multiple Climate Control Configurations Available (featured cab is shown with available options)



Ergonomic & Serviceable Joystick (Standard)



Fully Adjustable Air Suspended and Heated Seat (Standard)



Seven Inch Display (Standard)



Adjustable, Ergonomic Armrest that is Independent from Seat (Standard)



Industry's Toughest Steer Axle (Standard)



Vehicle Information Package "VIP" (Standard)

NEED OPTIONS?

Just ask one of our Taylor Specialist.

Taylor Machine Works was founded on the promise of meeting our customer's needs. The signage on our original facility in 1927 stated "We Engineer and Build What You Need" and those ideals still ring true today! From multiple Mast, Carriage and Fork configurations to Special Attachments that are unique to your business, we will step forward to meet the challenge. We have a dedicated engineering group focused on meeting special request from our customers. This ensures that you have the exact equipment you need to tackle your rugged applications. With hundreds of options readily available for our trucks, and the ability to custom engineer any other need that arises, Taylor Machine Works is here ready to serve.

Durability and Service

Taylor Empty Container Handlers are designed with ease of maintenance and serviceability as a key priority. With today's engine and emissions requirements, daily maintenance checks and timely periodic service are the key to your equipment's longevity. All GTX empty container handlers are certified by a major international third-party inspection and verification institute and are fully compliant with standard DIN 15018/H2 B4 Classes. This machine is engineered to resist the heaviest applications in the harshest environments. The GTX empty container handler's modular design is utilized throughout the range. This design increases reliability and parts availability. The standard sliding cab provides complete access to the engine and transmission bays. To maximize service convenience, fluid level check and refill points are easily accessible by a wide and safe standing platform. By using CAN-BUS components, the electronics have been reduced to a minimum. They are safely enclosed in an IP67 proof casting, and the cabling is certified to -40 degree temperature.

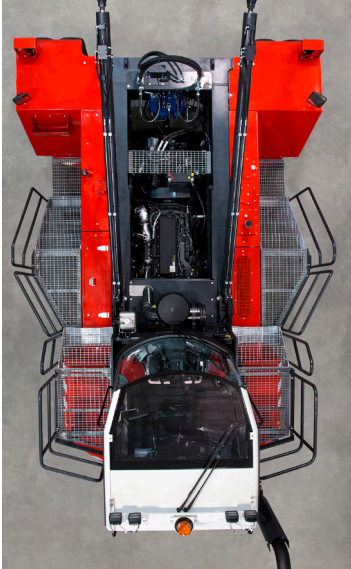

Easy Access to Drive Train & Hydraulics

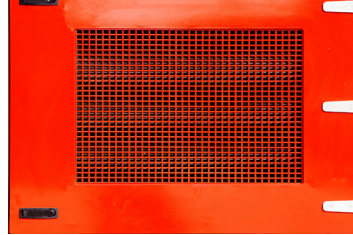

Large Hydraulic & Transmission Oil Cooling System

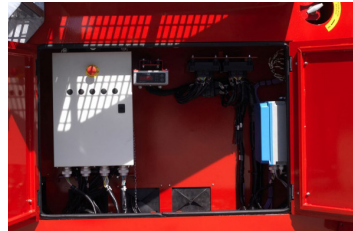

All-Weather Proof Connectors and Junction Boxes (Standard)



Hydraulics

The GTX-205/6 incorporates electronic controlled hydraulics. Load sensing distribution valves, managed by the Sixth Sense software, react quicker to power demand and modulation than conventional systems. Sixth Sense is included in the standard Energy Savings Solutions (ESS) package that eliminates unnecessary fuel consumption without impairing productivity. Other standard features on the ESS package are smart engine RPM management, hydraulic driven aircon compressor, and cab temperature management as well as thermostatically controlled fans.

On Board Computer System

All the GTX machines are equipped with a powerful on-board computer that provides the driver with operational aids and enhanced safety awareness. The system also allows a detailed user-friendly diagnostic of the machine's main systems and records functional and operational events. The core of the system is its color, extra wide 7-inch display. Interaction with the system is made through the function buttons (located on the sides) and the navigation buttons (located on the bottom).



DISCLAIMER:

This vehicle is certified to meet the applicable design and performance criteria required for Powered Industrial Trucks in OSHA Safety and Health Standards, Title 29 CFR, Part 1910.178, and the applicable design and performance requirements in ANSI B56.1 that were in effect at the time of manufacture. These standards also apply to the user and should be adhered to while operating this vehicle.

All specifications are subject to change without notice. Some operating data may be affected by the condition of the vehicle, how it is operated and the nature and condition of the operating area. If these specifications are critical, contact the factory.



www.taylorsuddenservice.com

24/7 Worldwide Support

No-one can match our record for service and reliability.
Unbeatable customer service, backed by over 90 years of customer satisfaction.



Taylor Machine Works, Inc.
3690 North Church Avenue
Louisville, MS 39339
www.taylorforklifts.com